

# Spark Resistant PackMaster™ Air Product Manual



# Spark Resistant PackMaster™ Air

**ALWAYS wear safety goggles or protective eyewear when operating the unit!**

## TABLE OF CONTENTS

Precautionary Warning.....	Page 1
Assembly.....	Page 2
Operation.....	Page 5
Parts List.....	Page 6
Control Arm.....	Page 7
Warranty.....	Page 8

## Thank you!

Congratulations on your purchase of the PackMaster™ Air industrial trash compactor.

Please take some time to read over the instructions and make sure you have all the necessary parts before assembling. Once assembled, you will have an efficient tool to reduce waste volume for many years.

Please check the serial number on your unit. This Manual is for units with serial number 1024051 and above only. For units with serial numbers below 1024051, please contact Newstripe for the correct manual.

# Spark Resistant PackMaster™ Air

**ALWAYS wear safety goggles or protective eyewear when operating the unit!**



## PRECAUTIONARY WARNING!

- Please read and understand **all** operation instructions as detailed in this manual. Failure to follow specified instructions may result in equipment damage or severe injury to personnel.
- Unit is not designed for crushing of glass containers or items that may shatter or contain volatile vapors.
- Keep compacted waste drums away from heat, sparks, and flame.  
No Smoking.
- Always consult your Facility Safety and/or Personnel Department for specified safety protocols prior to operating this equipment.
- Dropping the safety control arm at any time will stop the movement of the ram plate.
- Do not remove, modify, or change controls in any way. Never alter or change the equipment design.
- Keep arms & hands away from the compactor ram and drum lip while compacting. Failure to do so may cause personal injury.
- Do not exceed 150 psi as damage to the unit or operator may result.
- Always make sure the air supply line is disconnected before performing any cleaning of the compactor. With the air supply disconnected, the ram plate may gradually lower after an extended period.
- The air cylinder mounting plate must be mounted on the underside of the uprights.
- Do not permanently bolt the PackMaster™ to the floor as damage to the unit and personal injury may occur.



# Spark Resistant PackMaster™ Air

**ALWAYS wear safety goggles or protective eyewear when operating the unit!**

## Assembly

### Your PackMaster™ Air package contains the following:

- Base Plate
- Upright Arms (2)
- Air Cylinder
- Air Cylinder Mounting Plate
- Ram Plate
- Control Arm & Mounting Bracket

### Parts Bag Containing:

- ½" x 2" Long Bolts (5)
- ½" x 1 ½" Long Bolt (5)
- ½" Washers (16)
- ½" Locking Nuts (10)

1. Set the base plate on the floor. The four small holes in the top should be positioned to the rear.
2. Mount the uprights to the base plate, with the foot guards in between, using (4) ½" x 1 ½" long bolts, (8) ½" washers, and (4) locking nuts. Place one washer on the top and one on the bottom. Snug the nuts but not fully tighten them. This allows the uprights to be aligned with the bolt holes in the air cylinder mounting plate (Step 3)

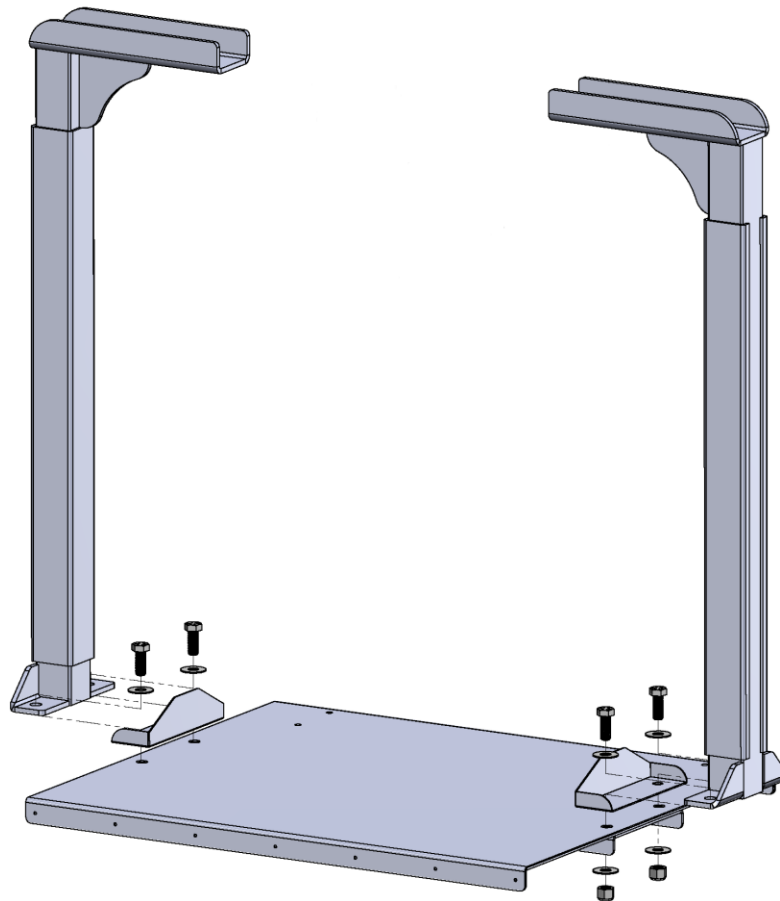

## Spark Resistant PackMaster™ Air

**ALWAYS wear safety goggles or protective eyewear when operating the unit!**

3. Install the shoulder/arm and the cylinder plate to the two uprights using (1) ½” x 1 ½” long bolts, (2) ½” washers, and (1) locking nut on the right side, and (1) ½” x 2” long bolts, (2) ½” washers, and (1) locking nut on the left side with the shoulder.

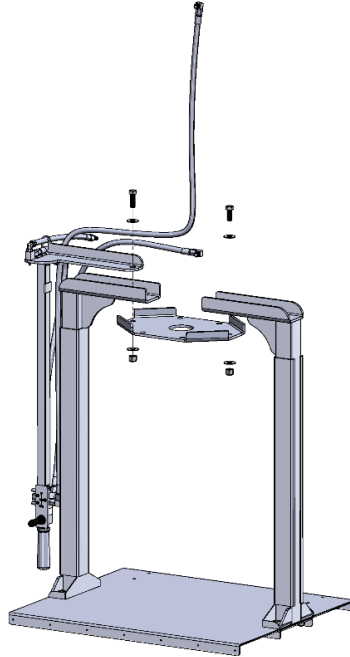

4. Mount the air cylinder to the air cylinder mounting plate using (4) ½” x 2” long bolts, (4) ½” washers on the bottom side, and (4) locking nuts. The air supply fittings should face away from you. Tighten all air cylinder assembly and upright mounting bolts.

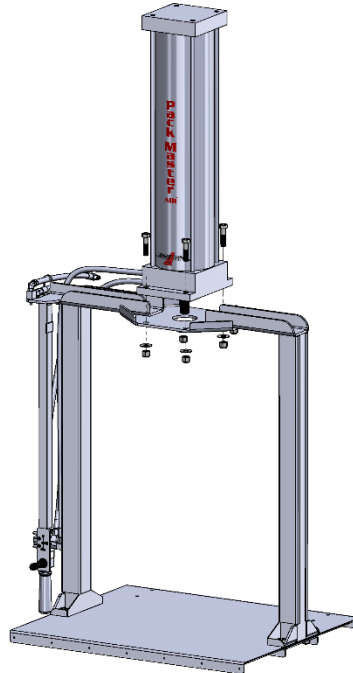

## Spark Resistant PackMaster™ Air

**ALWAYS wear safety goggles or protective eyewear when operating the unit!**

7. Connect the air hoses to the fittings on the backside of the air cylinder.



8. Check that the jam nut is spun all the way up on the air cylinder rod threads by hand. Thread the ram plate onto the air cylinder rod until it is snug. Spin the jam nut back down against the ram plate and tighten it.

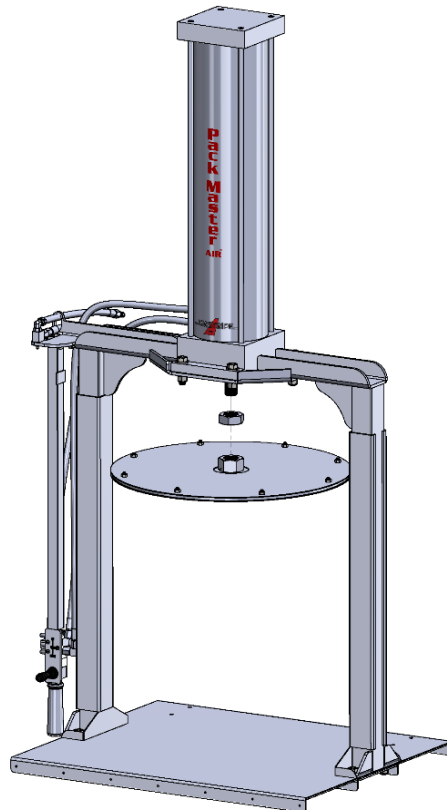

# Spark Resistant PackMaster™ Air

**ALWAYS wear safety goggles or protective eyewear when operating the unit!**

## CONNECTING THE AIR SUPPLY

The PackMaster Air is supplied with a pigtail hose and standard disconnect fitting, so it may be coupled to an air supply hose. You may remove the pigtail hose if the unit is stationary, and you wish to hard-plumb the unit to an air supply line.

**Your Pack-Master™ Air compactor is now ready for operation.**

## OPERATION

1. To operate the PackMaster™ Air, connect the compactor air supply line to any compressed air source up to a MAXIMUM of 150 psi. (Minimum 85 psi)
2. Lift the safety control arm to a horizontal position, against the stop. This assures that the safety control valve is completely depressed. The safety control valve must be depressed for the unit to operate.
3. Move the ram control valve lever toward the handle end, (backwards) to lower the ram. Release the ram control valve lever, and the ram plate will stop. Move the ram control valve lever toward the unit (forward) to raise the ram. The control arm must be continuously held in the horizontal position to engage the safety valve for the ram plate to move.



# Spark Resistant PackMaster™ Air

**ALWAYS wear safety goggles or protective eyewear when operating the unit!**

## PARTS LIST

<u>Item Number</u>	<u>Description</u>	<u>Part Number</u>	<u>Item Number</u>	<u>Description</u>	<u>Part Number</u>
1	Upright	10000988	8	Air Hose, Control 44-1/2"	10001422
2	Base Plate	10004974	9	Safety Control Arm	10005139
3	Bracket, Control Arm	10001018	10	Ram Control Valve (Joystick)	10005138
4	Air Hose, Supply, 12"	10001421	11	Safety Control Valve	10000609
5	Air Hose, Lower, 56"	10001423	12	Air Cylinder	10001846
6	Air Hose, Upper, 75"	10004150	13	Ram Plate 20"	10004173
7	Air Cylinder Plate	10001019	14	Jam Nut	10001353
			15	Handle Grip	10001827

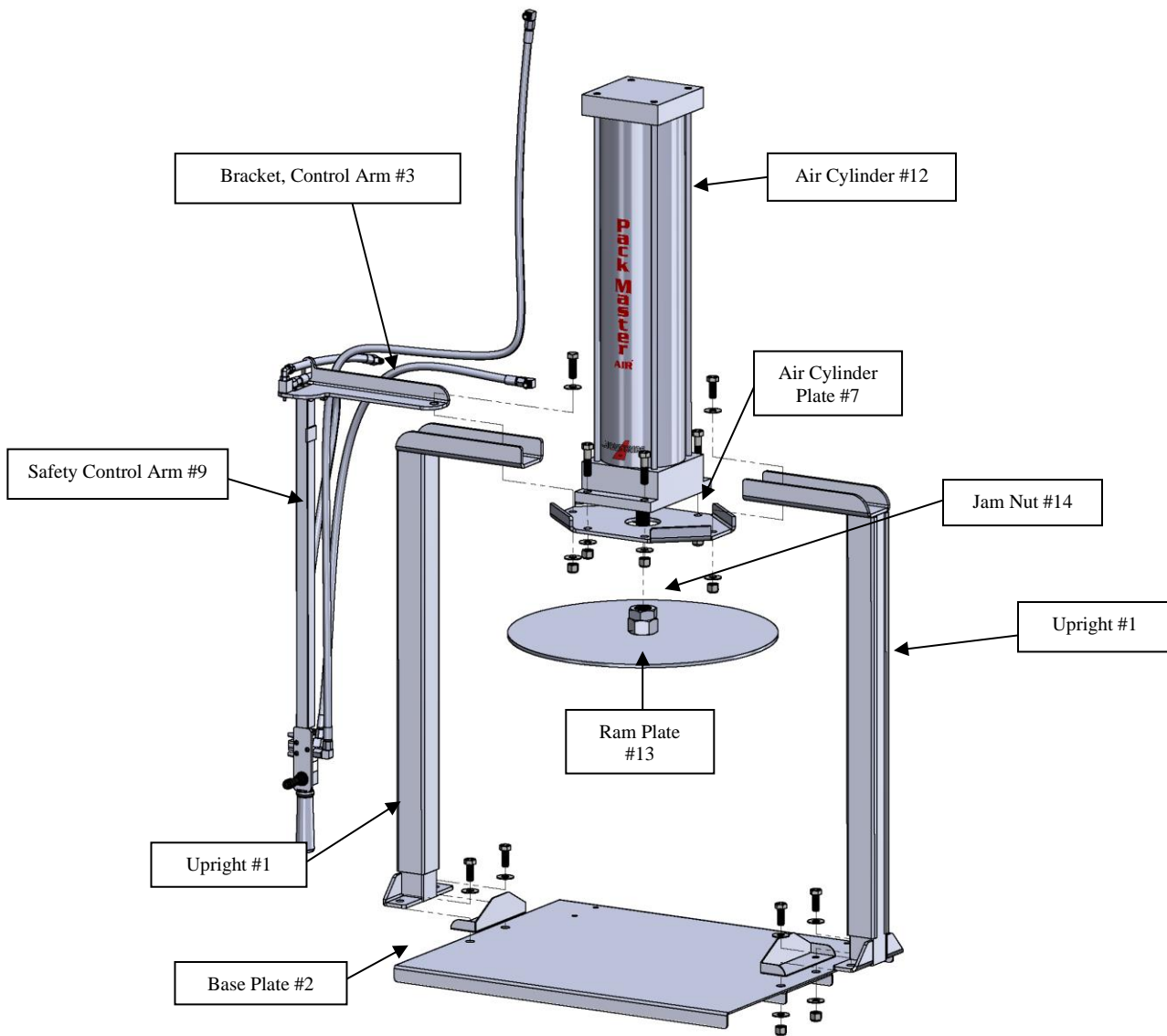

1700 Jasper St., Unit F, Aurora, CO 80011 T 800.624.6706 F 303.364.7796 • Newstripe.com

Spark Resistant Pack-Master™ Air Owner's Manual / 1453.1023



# Spark Resistant PackMaster™ Air

**ALWAYS wear safety goggles or protective eyewear when operating the unit!**

## PackMaster™ Air Control Arm Assembly

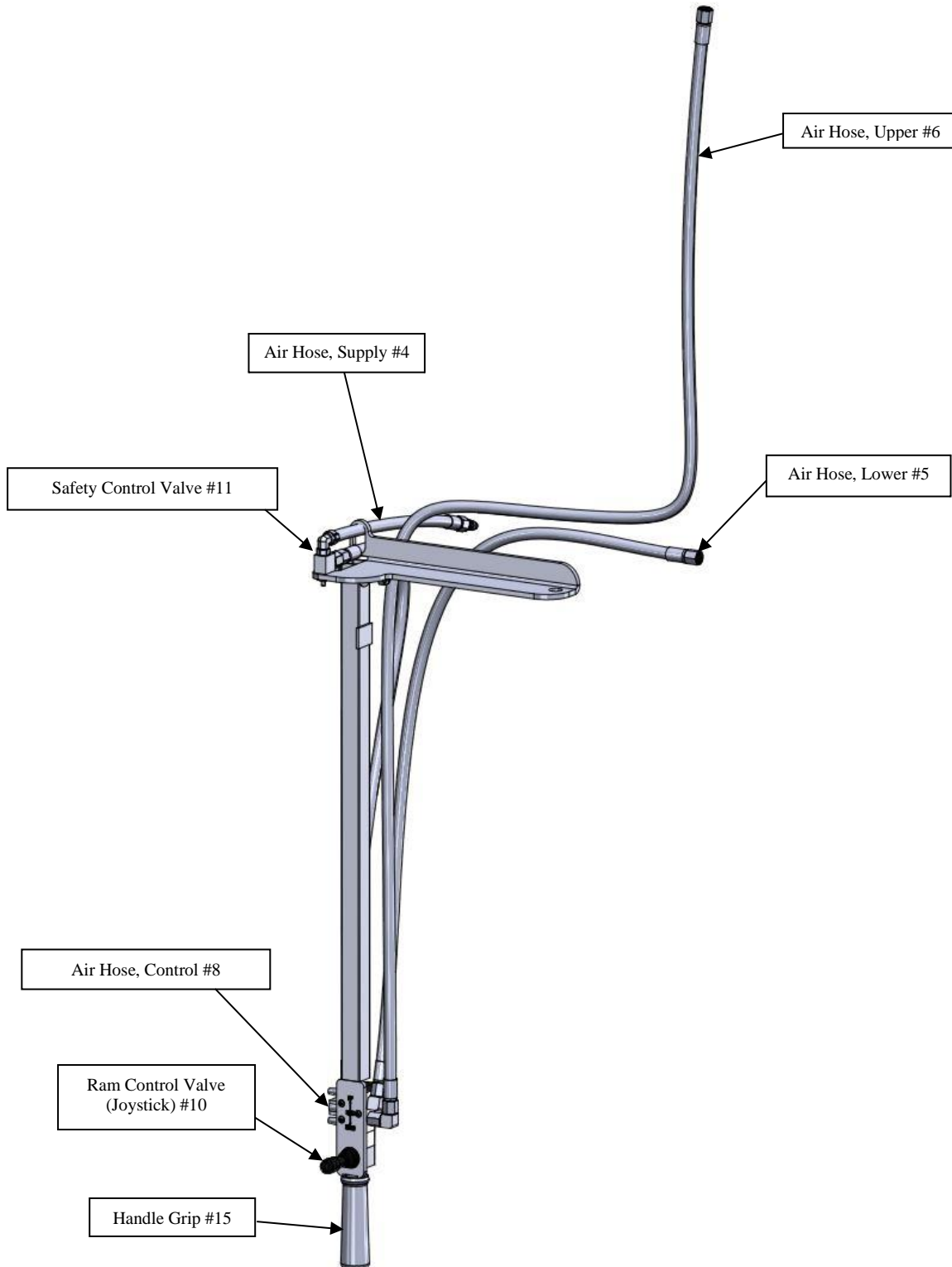

# Spark Resistant PackMaster™ Air

**ALWAYS wear safety goggles or protective eyewear when operating the unit!**

## THE NEWSTRIPE WARRANTY – 18 MONTH

NEWSTRIPE, INC., WARRANTS TO THE ORIGINAL PURCHASER, FOR 18 (EIGHTEEN) MONTHS AFTER THE DATE OF PURCHASE, THAT THE EQUIPMENT\* HEREBY SOLD SHALL BE FREE OF DEFECTS IN MATERIALS AND WORKMANSHIP. THIS WARRANTY DOES NOT EXTEND TO ANY DAMAGE OR MALFUNCTION RESULTING FROM MISUSE, NEGLIGENCE, ACCIDENT, IMPROPER OPERATION, OR NORMAL WEAR AND TEAR.

Damage incurred in shipment from Newstripe, Inc. to the customer is the total responsibility of the carrier. The CUSTOMER MUST NOTE DAMAGES on the Bill of Lading of Trucking Company or Railroad; and Newstripe, Inc. will furnish to the customer the cost or parts and labor. The customer can then bill the common carrier for the damages by placing his signature on the documents.

The Newstripe, Inc. obligation under this warranty and any implied warranties is limited to replacement or repair of defective parts of its manufacture without charge for 18 (Eighteen) months from date of purchase. For service under this warranty, the buyer shall ship the defective part or parts of the equipment, transportation prepaid, to Newstripe, Inc. together with a written description of any claimed defect and proof of purchase date of the materials being returned. **Prior to retuning any part or machine, the CUSTOMER must obtain a Return Materials Authorization number. Call 1-800-624-6706. To review the complete guidelines for warranty and returns, please visit [www.newstripe.com/guidlinesforwarrantyandreturn](http://www.newstripe.com/guidlinesforwarrantyandreturn).**

**\*Gasoline engines, compressors, pumps (including airless) and Transaxles are furnished with their respective manufacturer's warranties only. Such components are not covered by any warranty of Newstripe, Inc. Where Newstripe elects to extend manufacturers' warranties, the warranty shall be pro-rated as to cover 100% of the cost to replace or repair materials and parts for the first 12 months of ownership and 60% for the remaining 6-month period.**

The responsibilities described above are the only responsibilities of Newstripe, Inc. under this written warranty or any implied warranty, and may be exercised only within 18 (Eighteen) months from the date of purchase. In no event shall Newstripe, Inc. be liable for incidental or consequential damages and no person had any authority to bind it to any representation or warranty, not be responsible for work done, materials furnished, or repairs made by others without its' specific written authorization.

THIS WARRANTY SHALL BE IN LIEU OF ANY AND ALL OTHER WARRANTIES, EXPRESSED OR IMPLIED, INCLUDING ANY WARRANTIES OF MERCHANTABILITY OR FITNESS FOR A PARTICULAR PURPOSE, AND THERE IS NO OTHER REPRESENTATION OR WARRANTY OF ANY KIND WITH RESPECT TO THE GOODS SOLD HEREBY EXCEPT AS SET FORTH HEREIN. IT IS EXPRESSLY AGREED THAT THIS WARRANTY SHALL BE LIMITED TO THE ADJUSTMENT, REPAIR OR REPLACEMENT OF PARTS AND THE LABOR AND SERVICES REQUIRED THEREBY. IN NO EVENT, INCLUDING ANY CLAIM FOR NEGLIGENCE, SHALL NEWSTRIPE, INC. BE LIABLE FOR INCIDENTAL OR CONSEQUENTIAL DAMAGES.

Sincerely,  
**Newstripe, Inc**

